



RBS 5050 BF 5P 1.0 C

OD: 50.25" x 50.125" x 77.75"

Enclosure: up to 48.125" x 72.75"

*Threshold: 1" Change of Level**

Handed By: Center Drain

Weight: 492

Load Factor: 2.66

Truck Load Factor: .80

* Change of Level Threshold has a manageable 1/4" vertical rise to easily coordinate with minimum finished flooring.

MULTI-PIECE SHOWERS

APPLICATIONS

Residential Home Modifications & Commercial Facility Renovations

SHOWER FEATURES

- White Premium Marine-Grade Gelcoat
- 8" x 8" Tile Pattern
- Five Piece Remodeling Shower
- Self-Supporting & Pre-leveled Base™ Shower Base (Barrier Free units only)
- Shower Door Friendly
- Thirty Year Warranty
- In Stock for Rapid Delivery
- Accessories are Optional

CODE COMPLIANCE

IPC, UPC, ANSI Z 124.2, NAHB, HUD, FHA, VA

SAFETY FEATURES

- Plywood Reinforced Walls - For Placing Grab Bars & Seats Anywhere!
- Barrier Free or Easy Step Dam
- Grip Sure™ Floor

CONTRACTOR FRIENDLY FEATURES

- Installs from the Front
- Integral Self-Locating Metal Guide Pins
- Precision Fit Seams
- Seam Becomes Grout-Line
- Pre-Leveled Base™ - No Mudset Required (Barrier Free units only)
- Compact, Durable Individual Carton Packaging for Easy Handling at the Jobsite
- Heavy Duty Crating protects product in transit

30 YEAR LIMITED WARRANTY THE NEW STANDARD IN QUALITY

Where Warranty meets quality is where you find Renovative Bath Systems. Uncommon in the industry, all our RBS showers and shower pans are offered with an unprecedented 30 year limited warranty.

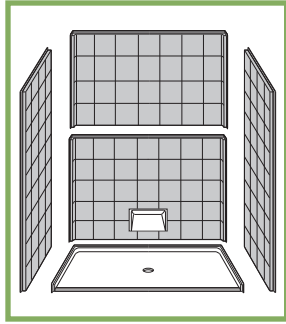

RBS 5050 BF 5P 1.0 C

OD: 50.25" x 50.125" x 77.75"

Enclosure: up to 48.125" x 72.75"

Threshold: 1" Change of Level*

Handed By: Center Drain

* Change of Level Threshold has a manageable 1/4" vertical rise to easily coordinate with minimum finished flooring.

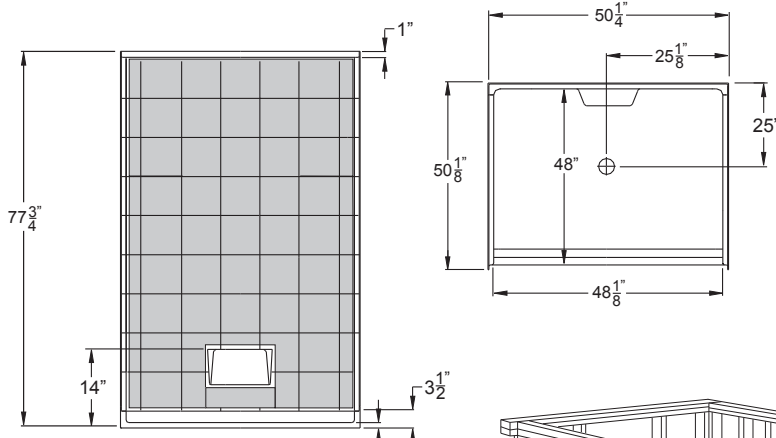

Gray shading represents plywood reinforced walls

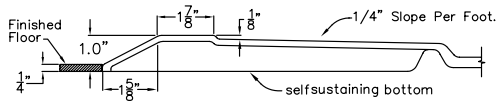

	A	B	C	D
5050 5P	50 1/2"	25 1/4"	50 1/4"	25 1/8"

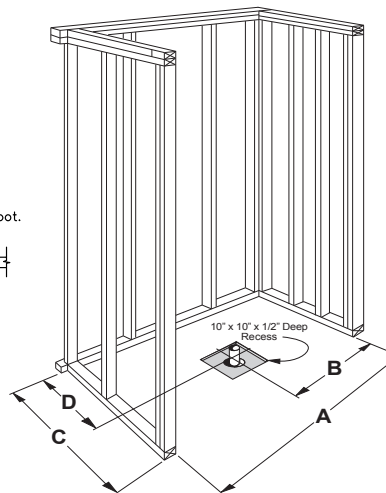

PACKAGING DETAILS



- Compact, Durable Carton Packaging for Easy Handling

- Ships LTL Truck in four business days for orders of two or less.

- For orders of two or more, call customer service for lead times.

- Accessories are shipped loose for field installation.



OPTIONAL ACCESSORIES

Grab Bars - Shipped Loose For Field Installation

- 18" Grab Bar - Stainless Steel
- 18" Grab Bar - White
- 24" Grab Bar - Stainless Steel
- 24" Grab Bar - White
- 36" Grab Bar - Stainless Steel
- 36" Grab Bar - White
- 42" Grab Bar - Stainless Steel
- 42" Grab Bar - White

Decorative Bars - Shipped Loose For Field Installation

- 24" Decorative Bar - Oil Rubbed Bronze
- 24" Decorative Bar - Satin Nickel
- 24" Decorative Bar - Polished Brass
- 24" Decorative Bar - Chrome

Additional Loose Accessories - For Field Installation

- Seat-Padded 24" x 16" with Four Fold-Down Legs
- Anti-Scald Valve - Chrome
- Slide Bar / Hand Held Shower
- Premium Anti-Bacterial Nylon Weighted Curtain (Off-White)
- Curtain Rod - Stainless Steel or White
- L-Shaped Curtain Rod - Stainless Steel (for 6060 3P DE)
- Collapsible Dam with Horizontal Endcaps - White (for Barrier Free models)
- Collapsible Dam with Vertical Endcaps - White (for 6030 & 5430 models)
- Semi-Permanent Dam
- Caulkless Drain - Stainless Steel
- Flange Trim Molding Kit



CUSTOMER SERVICE
800.441.8673

Richmond, VA
www.renovativebath.com